



A-T Controls, Inc.

# POWER-SEAL

Manual and Automated  
High Performance Butterfly Valves

ANSI/ASME Class 150# and 300#



Featuring **TRIAC**<sup>®</sup> Actuators and Accessories  
CONTROLS



Manual and Automated  
High Performance Butterfly Valves  
ANSI/ASME Class 150# and 300#



## Table of Contents

Page 3.....	Features and Benefits
Page 4.....	Seat Options
Page 5.....	Stem Packing Options and Benefits
Page 6.....	Cv Values and Operating Torques
Page 7.....	Bill of Materials
Page 8.....	Standard Materials of Construction Class #150
Page 9.....	Standard Materials of Construction Class #300
Page 10.....	Dimensions Class #150
Page 11.....	Dimensions Class #300
Page 12.....	Dimensions of Manual Handles and Gear Operators
Page 13.....	Component Rating / Pressure Temperatures
Page 14.....	How To Order (HPBFV Part Number Matrix)
Page 15.....	Accessories & Automation

**Square Stem**

Stem design facilitates direct mounting of pneumatic and electric actuators or gear operators through 12".

**Live Loaded Packing**

Power-Seal HPBFVs come standard with Live Loaded packing. Three sets of Belleville washers are added to each gland stud to maintain a self-adjusting packing load.

**Application Specific Stem Packing**

Standard packing is Graphite. Application specific options include: Double PTFE V-ring or Double PTFE Inverted packing.

**Internally Cast Travel Stop**

Travel Stop prevents over rotation of the disc in an effort to limit possible seat damage.

**Seat Retainer Design**

Seat retainer is designed so the fasteners do not interfere with the flange gasket sealing surface.

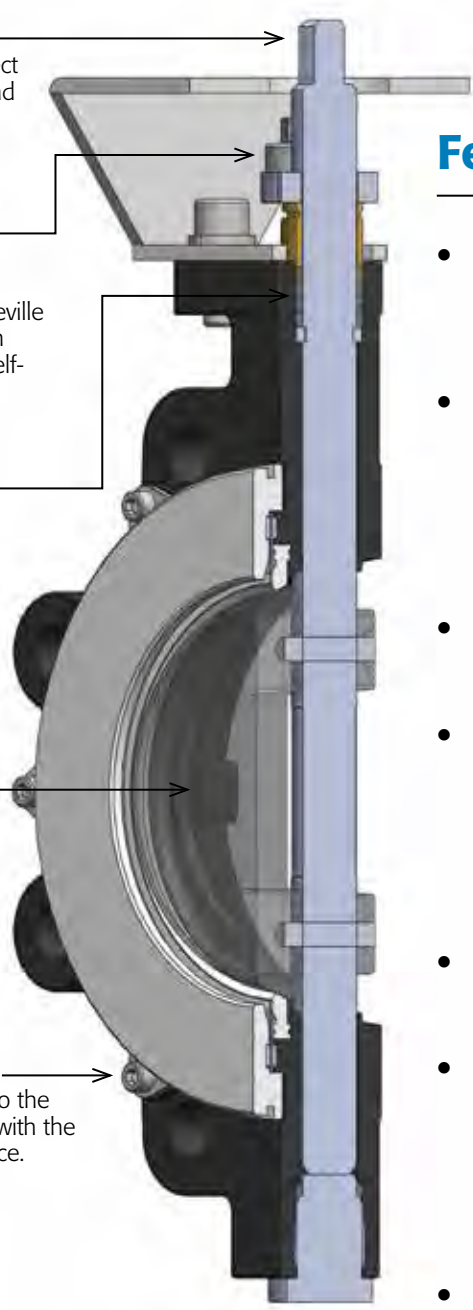

**Features and Benefits**

- Available inventory includes sizes 2"-24". Larger sizes (26"-48"+) are available upon request.
- Standard body materials are 316 SST or WCB. Application specific options include: Alloy 20, Monel, CD3MN, Hastelloy C, Inconel 625, Aluminum Bronze, LCB and others.
- ANSI/ASME Class 150# and 300# Lug and Wafer
- Standard seat materials are RTFE, RTFE/316L SST (Firesafe), and 316L SST (metal seat). Application specific seat materials include: 50/50 STFE, PTFE, PEEK, UHMWPE, TFM-1600 and Inconel 625.
- Standard Stem Material is 17-4 pH. Other options include 316 SST or XM-19.
- RTFE and Firesafe seat designs offer bubble-tight, bi-directional shutoff to full ANSI/ASME Class 150# and 300# standards. Metal seat design offers Class V shutoff.
- Blow out proof stem design

**Standards**

ANSI-B16.10	BS-6755
ANSI-B16.34	FCI 70-2
API-598	MSS SP-25
API-607	MSS SP-55
API-609	MSS SP-68
ASME-B16.5	

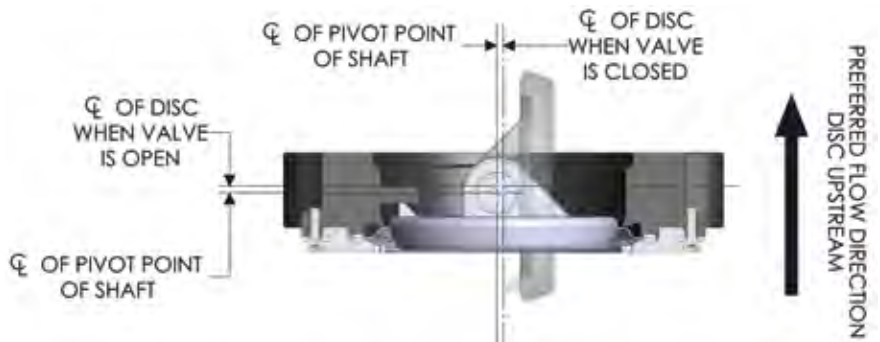

## POWER-SEAL High Performance Butterfly Valve seat designs:

- **PS Series** Soft Seat design
- **PF Series** RTFE/316L SST fire-safe seat design
- **PM/PH Series** Metal seat design for high temperature and specialized applications

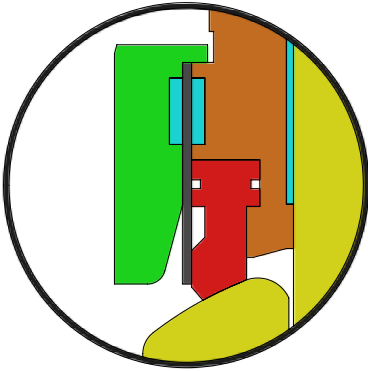

### PS Series

RTFE seat for bubble-tight shutoff of general purpose applications up to 450°F.\*

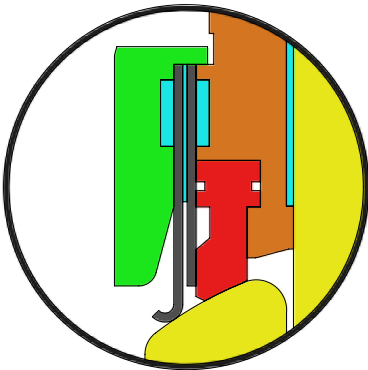

### PF Series

Primary RTFE seat for bubble-tight shutoff backed up by secondary 316L SST fire-safe seat. Secondary fire-safe seat provides Class V shutoff when primary RTFE seat is compromised in a fire event.\*

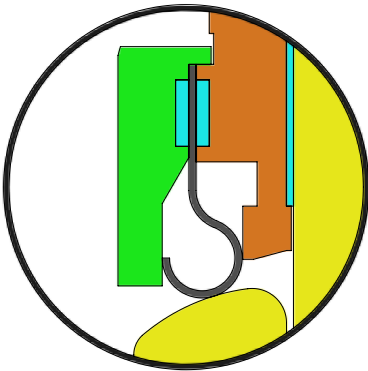

### PM/PH Series

316L SST seat for Class V shutoff of high temperature applications to 600°F (1100°F with Inconel 625 seat and 316 SST with Stellite disc).\*

\*Refer to Pressure Temperature Chart (pg. 13)

Standard  
RTFE Seat

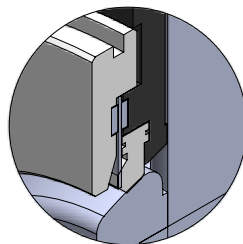

Firesafe - 316SST/RTFE  
(Rated to 450° F)

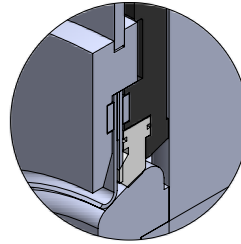

Metal - 316L SST Standard 600° F  
(Inconel 625 Optional 1100° F)

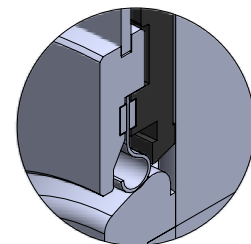

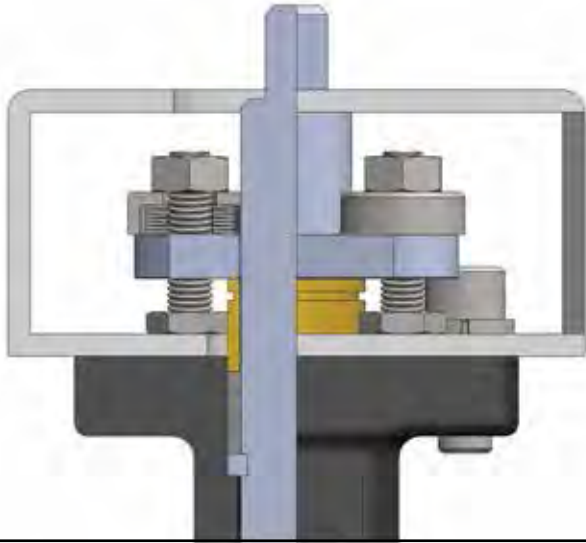
Stem Packing Options for **POWER-SEAL** High Performance Butterfly Valves**Graphite (G)**

Power-Seal High Performance Butterfly valves come standard with Live Loaded Graphite packing to accommodate a wide range of applications.

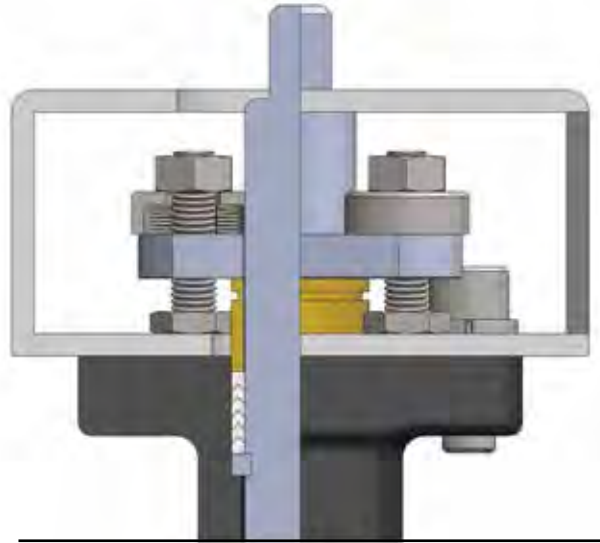
**PTFE V-Ring (P)**

Live Loaded Double Teflon Chevron packing for standard applications that are not compatible with graphite.

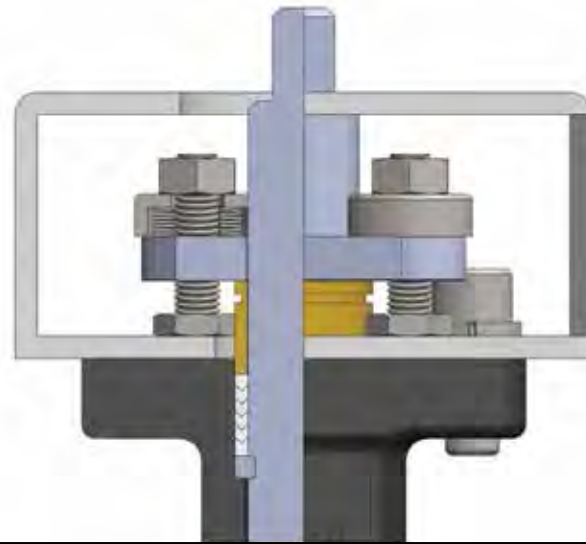
**PTFE Inverted V-Ring (V)**

Live Loaded Inverted Double Teflon Chevron packing will facilitate vacuum service applications.

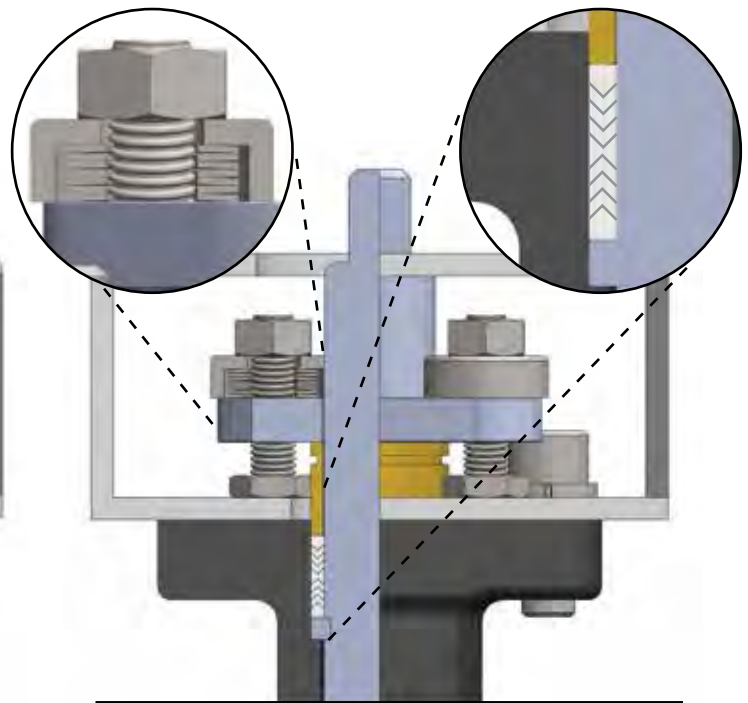
**Pressure/Vacuum V-Ring (D)**

Live Loaded Double Teflon Chevron packing comes together with Inverted Double Teflon Chevron packing to support applications of pressure and vacuum.

**Industry Leading High Performance Butterfly Valve Packing Design**

## Cv Values for **POWER-SEAL** High Performance Butterfly Valves

Class 150#			
Size	Fully Open Cv	Size	Fully Open Cv
2"	103	14"	6649
3"	210	16"	8533
4"	418	18"	10991
5"	731	20"	14069
6"	1132	24"	20977
8"	2268	30"	33965
10"	3715	36"	51016
12"	5486	42"	71010
		48"	96185

Class 300#			
Size	Fully Open Cv	Size	Fully Open Cv
2"	97	14"	5612
3"	211	16"	7840
4"	412	18"	9843
5"	728	20"	11834
6"	1054	24"	17965
8"	1987	30"	30169
10"	3184	36"	48225
12"	4633	42"	CF
		48"	CF

## Torque Charts for **POWER-SEAL** High Performance Butterfly Valves

### ANSI Class 150 LB (All torques in In-Lbs)

Valve Size	PS RTFE Seat		PF Firesafe RTFE/316L SST Seat		PM 316L SST Metal Seat	
	150 PSID	285 PSID	150 PSID	285 PSID	150 PSID	285 PSID
2"	135	160	160	190	170	205
2-1/2"	POA					
3"	360	408	435	490	470	535
4"	480	540	580	650	625	700
6"	970	1350	1175	1630	1270	1750
8"	2050	2750	2465	3335	2670	3600
10"	3150	4320	3800	5200	4100	5650
12"	4050	5650	4900	6800	5300	7380
14"	6300	8700	7625	10500	8260	11350
16"	9300	14700	11225	17750	12165	19200
18"	13000	18500	15500	22800	17230	24725
20"	19500	25000	23600	30950	25600	34500
22"	POA					
24"	33000	44000	39750	55000	43100	59600
30" +	POA					

Includes 20% safety

### ANSI Class 300 LB (All torques in In-Lbs)

Valve Size	PS RTFE Seat				PF Firesafe RTFE/316L SST Seat				PM 316L SST Metal Seat			
	150 PSID	300 PSID	500 PSID	740 PSID	150 PSID	300 PSID	500 PSID	740 PSID	150 PSID	300 PSID	500 PSID	740 PSID
2"	135	170	220	300	160	195	275	370	170	210	300	385
2-1/2"	POA											
3"	360	425	630	720	435	520	770	890	470	560	820	950
4"	480	565	850	950	580	690	1050	1150	625	740	1100	1235
6"	970	1390	1800	2050	1175	1700	2200	2500	1270	1830	2350	2665
8"	2050	2784	2900	3150	2465	3400	3550	3850	2670	3660	3785	4100
10"	3150	4550	5200	5900	3800	5560	6350	7200	4100	5990	6750	7675
12"	4050	5800	8100	9250	4900	7100	9900	11285	5300	7650	10530	12000
14"	6300	9025	15800	19500	7625	11050	19275	23800	8260	11900	20540	23350
16"	9300	15640	21200	25650	11225	19160	25900	31300	12165	20600	27500	33315
18"	13000	19600	27650	32125	15500	24000	33700	39190	17230	25800	36000	41765
20"	19500	36500	38100	43000	23600	33500	46500	52500	25600	35000	49500	55900
22"	POA											
24"	33000	47350	58000	62000	39750	58050	70750	75650	43100	62300	75400	80600
30" +	POA											

# Bill of Materials for **POWER-SEAL** High Performance Butterfly Valves

Item No.	Description	Material
1	BODY	*SEE STANDARD MATERIALS OF CONSTRUCTION (PAGE 8 AND 9)
2	DISC	*SEE STANDARD MATERIALS OF CONSTRUCTION (PAGE 8 AND 9)
3	SEAT	*SEE STANDARD MATERIALS OF CONSTRUCTION (PAGE 8 AND 9)
4	SEAT GASKET	WIRE REINFORCED COMPRESSED (NON ASBESTOS)
5	SEAT RING	STAINLESS STEEL
6	CLAMP PLATE (WAFER ONLY)	STAINLESS STEEL
7	RETAINER RING	CARBON STEEL/STAINLESS STEEL
8	CLAMPS	STAINLESS STEEL
9	CLAMP BOLTS	STAINLESS STEEL
10	BRACKET BOLTS	CARBON STEEL
11	BRACKET WASHER	CARBON STEEL
12	BRACKET	CARBON STEEL/STAINLESS STEEL
13	PACKING GLAND NUTS	STAINLESS STEEL
14	BELLEVILLE WASHER COVER	STAINLESS STEEL
15	BELLEVILLE WASHERS	CARBON STEEL
16	PACKING GLAND STUDS	STAINLESS STEEL
17	PACKING GLAND FLANGE	CARBON STEEL/STAINLESS STEEL
18	GLAND	304 SST
19	SHAFT UPPER PACKING	*SEE STANDARD MATERIALS OF CONSTRUCTION (PAGE 8 AND 9)
20	UPPER BEARING	METALPLAST (SS316+RTFE)/CARBON
21	THRUST BEARING	410 SST
22	SHAFT (2" & 3" HAVE TWO PIECE SHAFT)	*SEE STANDARD MATERIALS OF CONSTRUCTION (PAGE 8 AND 9)
23	DISC PIN	STAINLESS STEEL
24	LOWER BEARING	METALPLAST (SS316+RTFE)/CARBON
25	SHAFT LOWER PACKING	*SEE STANDARD MATERIALS OF CONSTRUCTION (PAGE 8 AND 9)
26	BOTTOM COVER	CARBON STEEL/STAINLESS STEEL
27	SECONDARY SEAT GASKET	ARAMID FIBER WITH NITRILE BINDER (NON ASBESTOS)
28	SECONDARY SEAT	*SEE STANDARD MATERIALS OF CONSTRUCTION (PAGE 8 AND 9)
29	RETAINER RING FIRE SAFE	CARBON/STAINLESS STEEL
30	METAL SEAT	*SEE STANDARD MATERIALS OF CONSTRUCTION (PAGE 8 AND 9)
31	RETAINER RING METAL SEAT	CARBON/STAINLESS STEEL

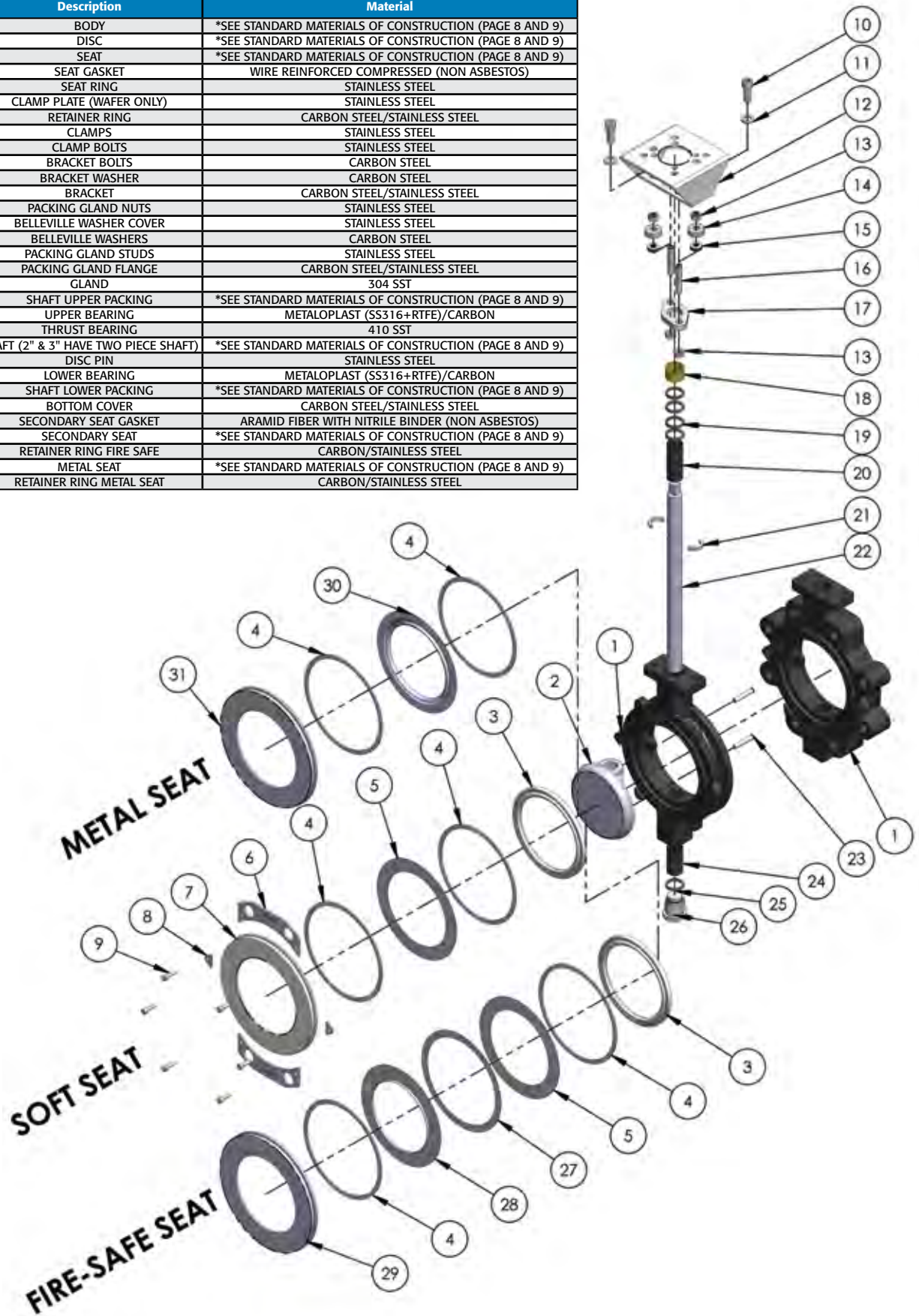

Standard Materials of Construction for **POWER-SEAL Class 150#****Soft Seat Materials**

Component	Carbon Steel Standard Material	Stainless Steel Standard Material	Options
Body	A216-WCB	A351 Gr CF8M-316	Alloy 20, Monel, CD3MN, Hast C, Inconel 625, Al-Bronze, LCB, Other
Disc	A351 Gr CF8M-316	A351 Gr CF8M-316	Same as body; except CS (316 standard)
Shaft	17-4 pH	17-4 pH	XM-19, 316 SST, K-Monel, Duplex 2205, Inconel 718
Seat	RTFE	RTFE	PTFE, 50/50, PEEK, UHMWPE, TFM-1600
Packing	Graphite	Graphite	Double PTFE (Pressure, Vacuum, Pressure/Vacuum)
Bearing	Composite	Composite	Bronze, Carbon Graphite

**Fire Safe Seat Materials**

Component	Carbon Steel Standard Material	Stainless Steel Standard Material	Options
Body	A216-WCB	A351 Gr CF8M-316	Alloy 20, Monel, CD3MN, Hast C, Inconel 625, Al-Bronze, LCB, Other
Disc	A351 Gr CF8M-316 / HCr	A351 Gr CF8M-316/ HCr	Same as body; except CS (316 standard)
Shaft	17-4 pH	17-4 pH	XM-19, 316 SST, K-Monel, Duplex 2205, Inconel 718
Seat	RTFE	RTFE	PTFE, 50/50, PEEK, UHMWPE, TFM-1600
Secondary Seat	A240-316L	A240-316L	
Packing	Graphite	Graphite	
Bearing	Composite	Composite	Bronze, Carbon Graphite

**Metal Seat Materials (Carbon Steel)**

Component	Carbon Steel Standard			Options
	Material (-20°F to 450°F)	Material (-20°F to 600°F)	Material (-20°F to 800°F)	
Body	A216-WCB	A216-WCB	A216-WCB	Alloy 20, Monel, CD3MN, Hast C, Inconel 625, Al-Bronze, LCB, Other
Disc	A351 Gr CF8M-316/ HCr	A351 Gr CF8M-316/ HCr	A351 Gr CF8M-316/ Stellite	
Shaft	17-4 pH	17-4 pH	17-4 pH	316 SST
Seat	A240-316L	A240-316L	Inconel 625	
Packing	Graphite	Graphite	Graphite	Double TFE to 450°F
Bearing	Carbon Graphite	Carbon Graphite	Carbon Graphite	Bronze

**Metal Seat Materials (Stainless Steel)**

Component	Stainless Steel Standard			Options
	Material (-100°F to 500°F)	Material (-100°F to 600°F)	Material (-100°F to 1100°F)	
Body	A351 Gr CF8M-316	A351 Gr CF8M-316	A351 Gr CF8M-316	Alloy 20, Monel, CD3MN, Hast C, Inconel 625, Al-Bronze, LCB, Other
Disc	A351 Gr CF8M-316/ HCr	A351 Gr CF8M-316/ HCr	A351 Gr CF8M-316/ Stellite	
Shaft	17-4 pH	17-4 pH	17-4 pH	XM-19, 316 SST
Seat	A240-316L	A240-316L	Inconel 625	
Packing	Graphite	Graphite	Graphite	Double TFE to 450°F
Bearing	Carbon Graphite	Carbon Graphite	Carbon Graphite	Bronze



Standard Materials of Construction for **POWER-SEAL Class 300#****Soft Seat Materials**

Component	Carbon Steel Standard Material	Stainless Steel Standard Material	Options
Body	A216-WCB	A351 Gr CF8M-316	Alloy 20, Monel, CD3MN, Hast C, Inconel 625, Al-Bronze, LCB, Other
Disc	A351 Gr CF8M-316	A351 Gr CF8M-316	Same as body; except CS (316 standard)
Shaft	17-4 pH	17-4 pH	XM-19, K-Monel, Duplex 2205, Inconel 718
Seat	RTFE	RTFE	PTFE, 50/50, PEEK, UHMWPE, TFM-1600
Packing	Graphite	Graphite	Double PTFE (Pressure, Vacuum, Pressure/Vacuum)
Bearing	Composite	Composite	Bronze, Carbon Graphite

**Fire Safe Seat Materials**

Component	Carbon Steel Standard Material	Stainless Steel Standard Material	Options
Body	A216-WCB	A351 Gr CF8M-316	Alloy 20, Monel, CD3MN, Hast C, Inconel 625, Al-Bronze, LCB, Other
Disc	A351 Gr CF8M-316 / HCr	A351 Gr CF8M-316/ HCr	Same as body; except CS (316 standard)
Shaft	17-4 pH	17-4 pH	XM-19, K-Monel, Duplex 2205, Inconel 718
Seat	RTFE	RTFE	PTFE, 50/50, PEEK, UHMWPE, TFM-1600
Secondary Seat	A240-316L	A240-316L	
Packing	Graphite	Graphite	
Bearing	Composite	Composite	Bronze, Carbon Graphite

**Metal Seat Materials (Carbon Steel)**

Component	Carbon Steel Standard			Options
	Material (-20°F to 450°F)	Material (-20°F to 600°F)	Material (-20°F to 800°F)	
Body	A216-WCB	A216-WCB	A216-WCB	Alloy 20, Monel, CD3MN, Hast C, Inconel 625, Al-Bronze, LCB, Other
Disc	A351 Gr CF8M-316/ HCr	A351 Gr CF8M-316/ HCr	A351 Gr CF8M-316/ Stellite	
Shaft	17-4 pH	17-4 pH	17-4 pH	XM-19
Seat	A240-316L	A240-316L	Inconel 625	
Packing	Graphite	Graphite	Graphite	Double TFE to 450°F
Bearing	Carbon Graphite	Carbon Graphite	Carbon Graphite	Bronze

**Metal Seat Materials (Stainless Steel)**

Component	Stainless Steel Standard			Options
	Material (-100°F to 500°F)	Material (-100°F to 600°F)	Material (-100°F to 1100°F)	
Body	A351 Gr CF8M-316	A351 Gr CF8M-316	A351 Gr CF8M-316	Alloy 20, Monel, CD3MN, Hast C, Inconel 625, Al-Bronze, LCB, Other
Disc	A351 Gr CF8M-316/ HCr	A351 Gr CF8M-316/ HCr	A351 Gr CF8M-316/ Stellite	
Shaft	17-4 pH	17-4 pH	XM-19	
Seat	A240-316L	A240-316L	Inconel 625	
Packing	Graphite	Graphite	Graphite	Double TFE to 450°F
Bearing	Carbon Graphite	Carbon Graphite	Carbon Graphite	Bronze

## Dimensions for **POWER-SEAL Class 150#**

**MOUNTING FOR VALVES 2"-12"**

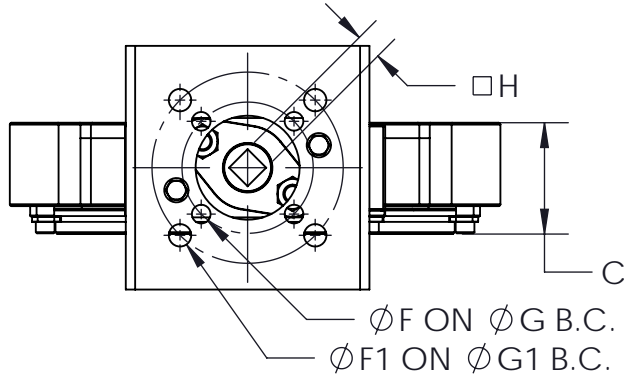

**MOUNTING FOR VALVES 14"-48"**

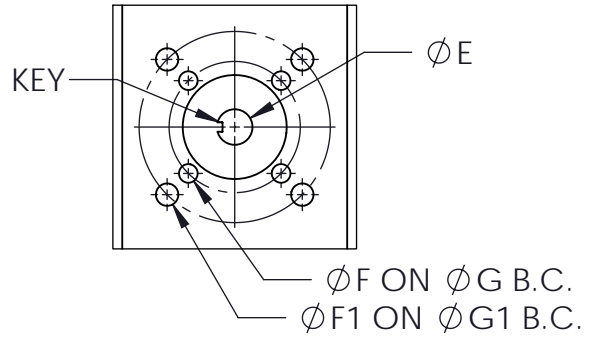

**WAFER STYLE BODY**

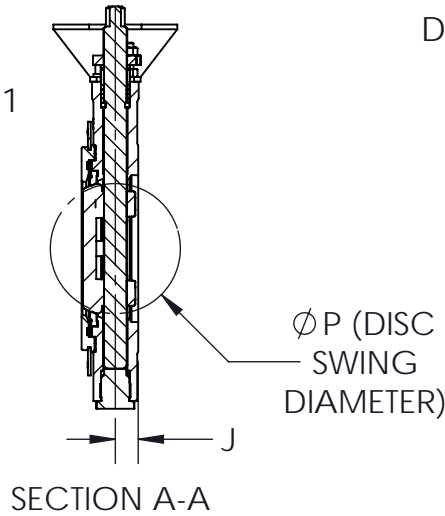
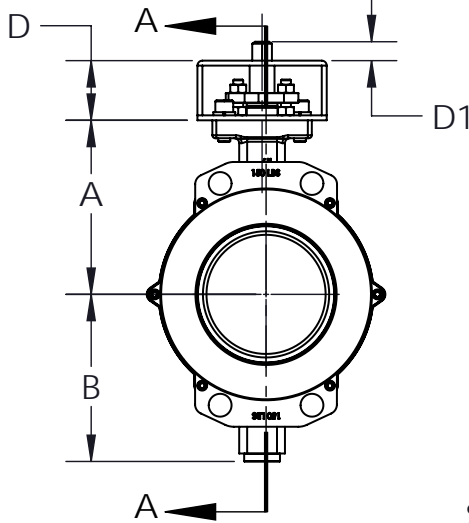

**LUG STYLE BODY**

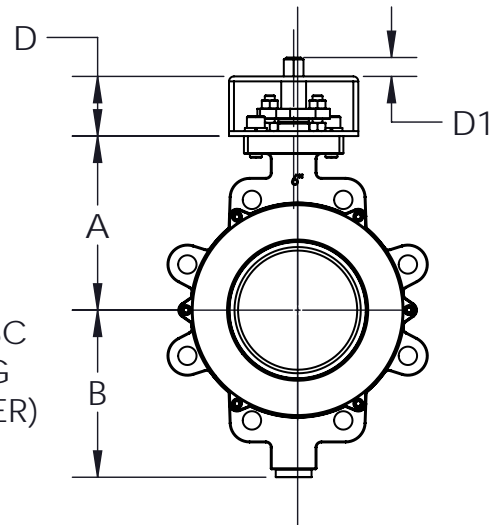

**ANSI/ASME Class 150#**

SIZE	A	B	C	D	D1	E	F	F1	G	G1	H	J	END CONNECTION	WAFER WEIGHT (Lbs)	LUG WEIGHT (Lbs)	P	KEY (mm)	ISO 5211
2"	4.33	3.94	2.09	2.36	0.71	NA	0.35	NA	2.756	NA	0.354	0.83	ANSI B 16.5 150LB	9	12	2.58	NA	F07
3"	5.24	4.84	1.89	2.76	0.75	NA	0.35	NA	2.756	NA	0.433	0.81	ANSI B 16.5 150LB	11	14	3.10	NA	F07
4"	5.71	5.31	2.13	2.76	0.83	NA	0.35	NA	2.756	NA	0.433	0.87	ANSI B 16.5 150LB	18	26	3.66	NA	F07
5"	6.50	6.38	2.20	2.76	0.83	NA	0.35	NA	2.756	NA	0.433	0.91	ANSI B 16.5 150LB	20	30	4.69	NA	F07
6"	6.89	6.61	2.24	2.76	0.83	NA	0.35	0.43	2.756	4.016	0.551	0.94	ANSI B 16.5 150LB	32	37	5.37	NA	F07/F10
8"	7.87	7.68	2.52	2.76	1.02	NA	0.43	NA	4.016	NA	0.748	1.06	ANSI B 16.5 150LB	45	49	7.34	NA	F10
10"	10.43	9.61	2.80	3.15	1.18	NA	0.43	0.51	4.016	4.921	0.748	1.10	ANSI B 16.5 150LB	72	92	8.86	NA	F10/F12
12"	11.42	10.55	3.19	3.15	1.18	NA	0.51	NA	4.921	NA	0.866	1.22	ANSI B 16.5 150LB	112	129	10.91	NA	F12
14"	12.20	11.57	3.62	3.54	2.17	1.181	0.51	NA	4.921	NA	NA	1.57	ANSI B 16.5 150LB	135	183	12.35	8X7	F12
16"	14.57	14.02	4.02	3.94	2.56	1.575	0.51	0.71	4.921	5.512	NA	1.78	ANSI B 16.5 150LB	182	250	14.50	12X8	F12/F14
18"	15.35	14.69	4.49	3.94	2.95	1.772	0.71	0.87	5.512	6.496	NA	1.97	ANSI B 16.5 150LB	235	306	16.46	14X9	F14/F16
20"	15.94	16.06	5.00	3.94	2.95	1.772	0.71	0.87	5.512	6.496	NA	2.17	ANSI B 16.5 150LB	325	420	18.36	14X9	F14/F16
24"	18.90	18.90	6.06	4.72	3.35	2.165	0.71	NA	8.071	NA	NA	2.52	ANSI B 16.5 150LB	505	705	22.25	18X11	F20
26"	23.03	20.28	6.50	4.72	4.13	2.559	0.71	0.71	8.071	10.000	NA	2.87	ANSI B16.47-SERIES A	580	763	23.88	18X11	F20/F25
28"	21.46	20.63	6.50	5.12	4.13	2.559	0.71	NA	10.000	NA	NA	2.82	ANSI B16.47-SERIES A	865	1060	26.00	18X11	F25
30"	24.02	21.65	7.48	5.12	4.13	2.559	0.71	NA	10.000	NA	NA	3.43	ANSI B16.47-SERIES A	930	1135	28.00	18X11	F25
32"	25.04	22.64	7.48	5.51	5.12	3.543	0.71	0.87	10.000	11.732	NA	3.43	ANSI B16.47-SERIES A	995	1215	30.00	25X14	F25/F30
36"	28.15	26.14	7.99	5.51	5.12	3.543	0.71	0.87	10.000	11.732	NA	3.90	ANSI B16.47-SERIES A	1650	1900	33.69	25X14	F25/F30
40"	29.13	29.25	8.50	5.91	5.12	3.543	0.87	1.26	11.732	14.016	NA	4.25	ANSI B16.47-SERIES A	2360	2580	37.72	25X14	F30/F35
44"	31.50	31.65	10.00	5.91	5.12	3.543	0.87	1.26	11.732	14.016	NA	4.72	ANSI B16.47-SERIES A	2600	2850	42.06	25X14	F30/F35
48"	35.04	34.29	10.00	5.91	5.91	4.331	1.26	1.50	14.016	15.984	NA	4.33	ANSI B16.47-SERIES A	2830	3100	45.25	32X18	F35/F40

Dimensions for **POWER-SEAL Class 300#**

**MOUNTING FOR VALVES 2"-12"**

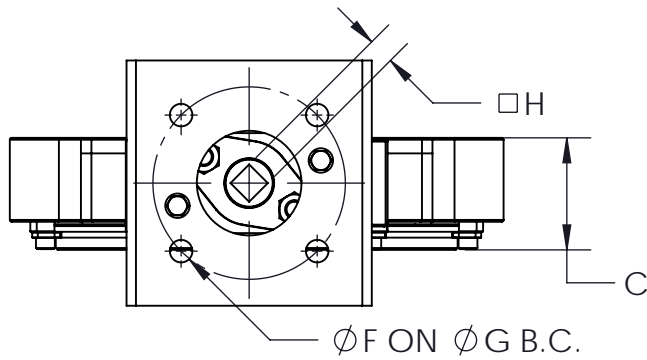

**MOUNTING FOR VALVES 14"-48"**

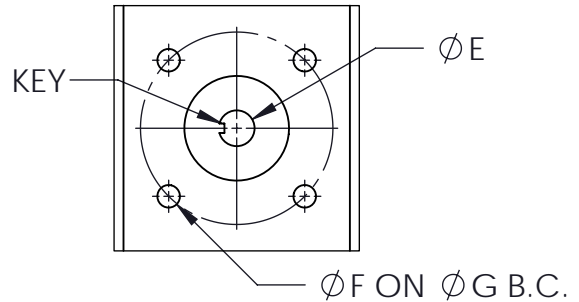

**WAFER STYLE BODY**

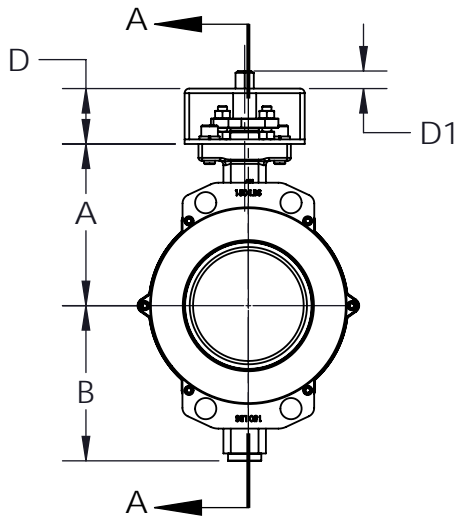

**LUG STYLE BODY**

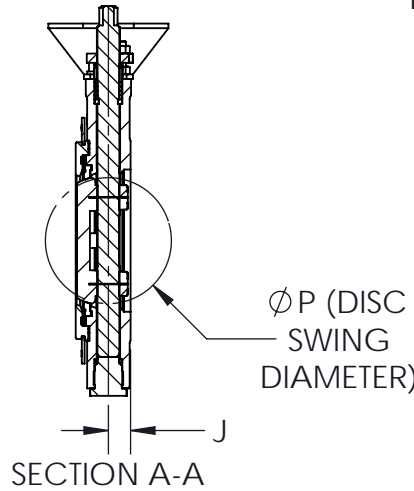
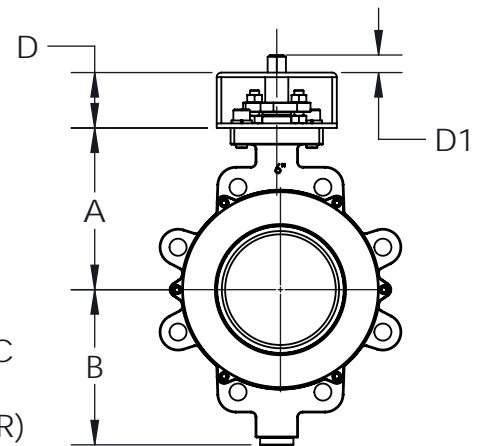

**ANSI/ASME Class 300#**

SIZE	A	B	C	D	D1	E	F	G	H	J	END CONNECTION	WAFER WEIGHT (Lbs)	LUG WEIGHT (Lbs)	P	KEY (mm)	ISO 5211
2"	4.33	3.94	2.09	2.36	0.71	NA	0.35	2.756	0.354	0.83	ANSI B 16.5 300LB	9	12	2.58	NA	F07
3"	5.24	4.84	1.89	2.76	0.75	NA	0.35	2.756	0.433	0.81	ANSI B 16.5 300LB	12	18	3.10	NA	F07
4"	5.71	5.31	2.13	2.76	0.83	NA	0.35	2.756	0.433	0.87	ANSI B 16.5 300LB	18	25	3.66	NA	F07
5"	6.50	6.38	2.20	2.76	0.83	NA	0.35	2.756	0.433	0.91	ANSI B 16.5 300LB	21	30	4.69	NA	F07
6"	6.89	6.61	2.32	2.76	0.83	NA	0.43	4.016	0.551	1.00	ANSI B 16.5 300LB	32	50	5.37	NA	F10
8"	8.27	8.03	2.87	2.76	1.02	NA	0.43	4.016	0.748	1.42	ANSI B 16.5 300LB	54	80	7.34	NA	F10
10"	10.43	9.61	3.27	3.15	1.18	NA	0.51	4.921	0.748	1.57	ANSI B 16.5 300LB	90	120	8.86	NA	F12
12"	12.20	11.18	3.62	3.15	1.18	NA	0.51	4.921	0.866	1.65	ANSI B 16.5 300LB	155	200	10.91	NA	F12
14"	13.39	12.76	4.61	3.54	2.17	1.18	0.51	4.921	NA	2.56	ANSI B 16.5 300LB	290	325	12.35	8X7	F12
16"	14.57	14.02	5.24	3.94	2.56	1.57	0.71	5.512	NA	2.76	ANSI B 16.5 300LB	340	405	14.50	12X8	F14
18"	15.94	15.55	5.87	3.94	2.95	1.77	0.87	6.496	NA	2.87	ANSI B 16.5 300LB	400	520	16.46	14X9	F16
20"	17.52	16.65	6.26	3.94	2.95	1.77	0.87	6.496	NA	3.11	ANSI B 16.5 300LB	515	740	18.36	14X9	F16
24"	20.04	20.08	7.13	4.72	3.35	2.17	0.71	8.071	NA	3.59	ANSI B 16.5 300LB	735	1025	22.25	18X11	F20
26"	23.03	21.46	6.50	4.72	4.13	2.56	0.71	10	NA	CF	ANSI B 16.47 SERIES A 300LB	CF	CF	23.88	18X11	F25
28"	23.23	22.44	6.50	5.12	4.13	2.56	0.71	10.000	NA	CF	ANSI B 16.47 SERIES A 300LB	CF	CF	26.00	18X11	F25
30"	25.79	24.02	7.48	5.12	4.13	2.56	0.71	10.000	NA	CF	ANSI B 16.47 SERIES A 300LB	CF	CF	28.00	18X11	F25
32"	26.57	25.20	7.48	5.51	5.12	3.54	0.87	11.732	NA	CF	ANSI B 16.47 SERIES A 300LB	CF	CF	30.00	25X14	F30
36"	28.15	26.14	7.99	5.51	5.12	3.54	0.87	11.732	NA	CF	ANSI B 16.47 SERIES A 300LB	CF	CF	33.69	25X14	F30
40"	29.13	30.43	8.50	5.91	5.12	3.54	1.26	14.016	NA	CF	ANSI B 16.47 SERIES A 300LB	CF	CF	37.72	25X14	F35
44"	31.69	31.65	10.00	5.91	5.12	3.54	1.26	14.016	NA	CF	ANSI B 16.47 SERIES A 300LB	CF	CF	42.06	25X14	F35
48"	35.04	34.29	10.00	5.91	5.91	4.33	1.40	15.984	NA	CF	ANSI B 16.47 SERIES A 300LB	CF	CF	45.25	32X18	F40

Dimensions for **POWER-SEAL** Manual Handles / Gear Operators

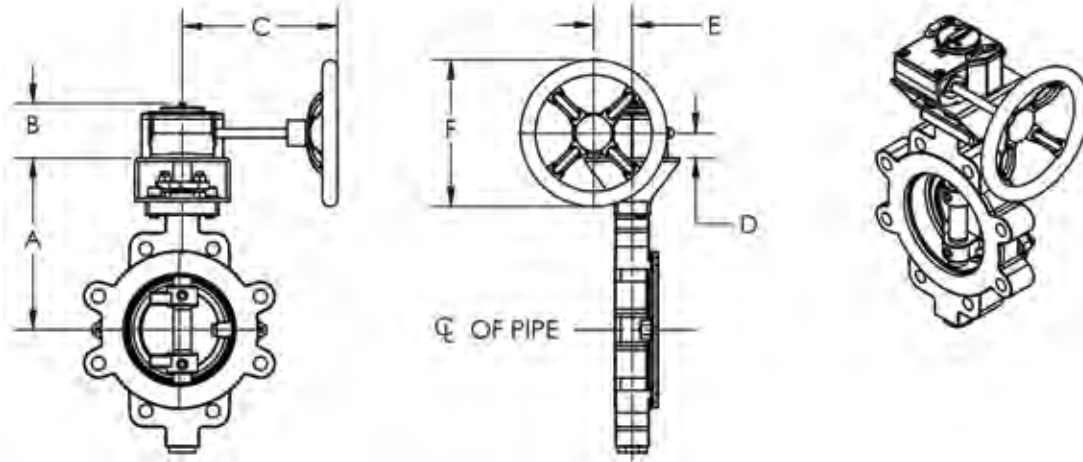

**150#**

SIZE	GEAR	A	B	C	D	E	F
2"	Q200-4	6.69	2.52	5.16	1.12	1.71	4
3"	Q200-4	7.99	2.52	5.16	1.12	1.71	4
4"	Q200-4	8.46	2.52	5.16	1.12	1.71	4
5"	Q400-4	9.25	2.94	7.12	1.34	2.07	4
6"	Q400-6	9.65	2.94	7.28	1.34	2.07	6
8"	Q800-12	10.63	3.56	10.24	1.67	2.71	12
10"	Q800-12	13.58	3.56	10.24	1.67	2.71	12
12"	Q800-16	14.57	3.56	11.71	1.67	2.71	16
14"	Q2000-16	15.75	3.94	12.64	1.97	3.8	16
16"	Q2000-20	18.5	3.94	13.39	1.97	3.8	20
18"	Q4000-20	19.29	5.04	16.07	2.15	5.41	20
20"	Q4000-27	19.88	5.04	17.61	2.15	5.41	27
24"	Q6500-16	23.23	5.04	16.58	2.15	5.41	16

**300#**

SIZE	GEAR	A	B	C	D	E	F
2"	Q200-4	6.69	2.52	5.16	1.12	1.71	4
3"	Q200-4	7.99	2.52	5.16	1.12	1.71	4
4"	Q200-4	8.46	2.52	5.16	1.12	1.71	4
5"	Q400-4	9.25	2.94	7.12	1.34	2.07	4
6"	Q400-6	9.65	2.94	7.28	1.34	2.07	6
8"	Q800-12	11.02	3.56	10.73	1.67	2.71	12
10"	Q800-16	13.58	3.56	11.71	1.67	2.71	16
12"	Q2000-16	15.35	3.94	12.64	1.97	3.8	16
14"	Q4000-20	16.93	5.04	16.07	2.15	5.41	20
16"	Q4000-27	18.5	5.04	17.61	2.15	5.41	27
18"	Q4000-27	19.88	5.04	17.61	2.15	5.41	27
20"	Q6500-16	21.46	5.04	16.58	2.15	5.41	16
24"	Q6500-20	24.76	5.04	17.33	2.15	5.41	20

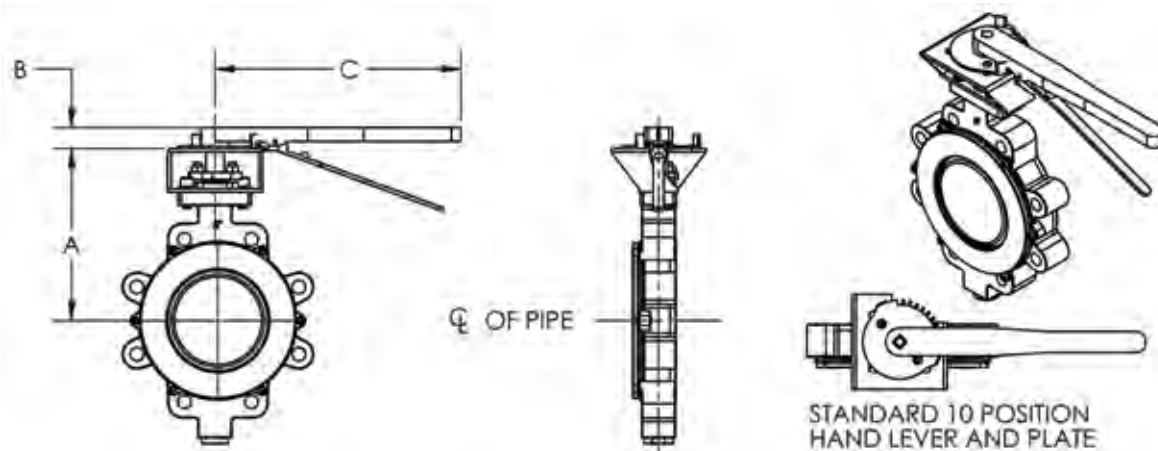

**150#**

SIZE	A	B	C
2"	6.69	1.02	11
3"	7.99	1.02	17
4"	8.46	1.02	17
5"	9.25	1.02	17
6"	9.65	1.14	17
8"	10.63	1.14	22

**300#**

SIZE	A	B	C
2"	6.69	1.02	11
3"	7.99	1.02	17
4"	8.46	1.02	17
5"	9.25	1.02	17
6"	9.65	1.14	17
8"	11.02	1.14	22

## Component Rating for **POWER-SEAL** High Performance Butterfly Valves

Description	Material	Temperature (°F)
Seat (Soft Seat)	PTFE	-50 to 360° F
	RTFE	-100 to 450° F
	50/50	-100 to 500° F
	PEEK	-20 to 500° F
	UHMWPE	-50 to 200° F
Seat (Firesafe)	RTFE/316L- HCr	-100 to 450° F
Seat (Metal)	Inconel 625	-100 to 1100° F
	316L SST	-100 to 600° F
Stem Packing	Graphite	-100 to 1100° F
	Double PTFE	-100 to 450° F
Stem	316 SST	-100 to 1100° F
	K-Monel	-100 to 1100° F
	17-4 pH	-100 to 1100° F
	XM-19	-100 to 1100° F
Bearings	Teflon® Composite	-50 to 400° F
	Bronze	-100 to 650° F
	Carbon Graphite	-100 to 1100° F
Disc Treatment	316L/HCr	-100 to 600° F
	Stellite 6	-100 to 1100° F

### Pressure Temperature Chart by Seats

#### Soft Seat

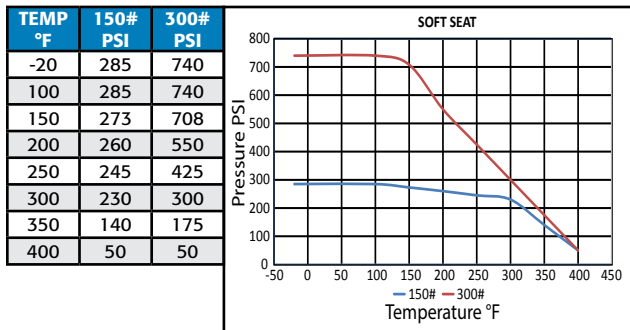

#### Firesafe

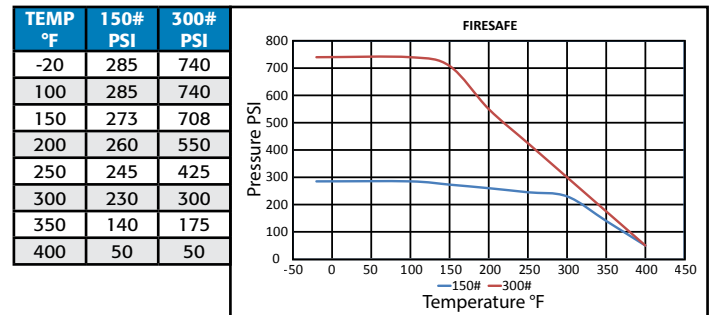

#### Metal Seat (316L SST)

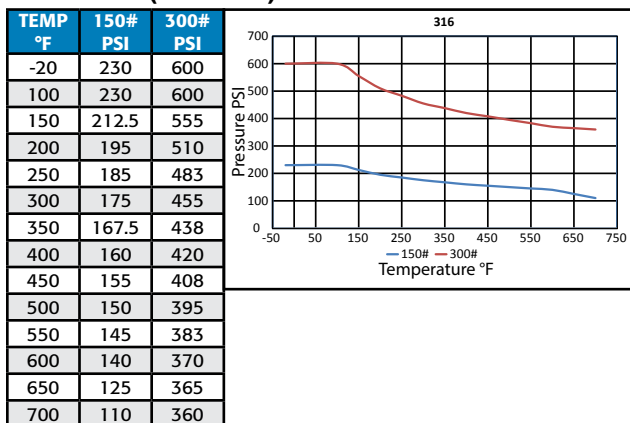

#### Metal Seat High Temp (Inconel 625)

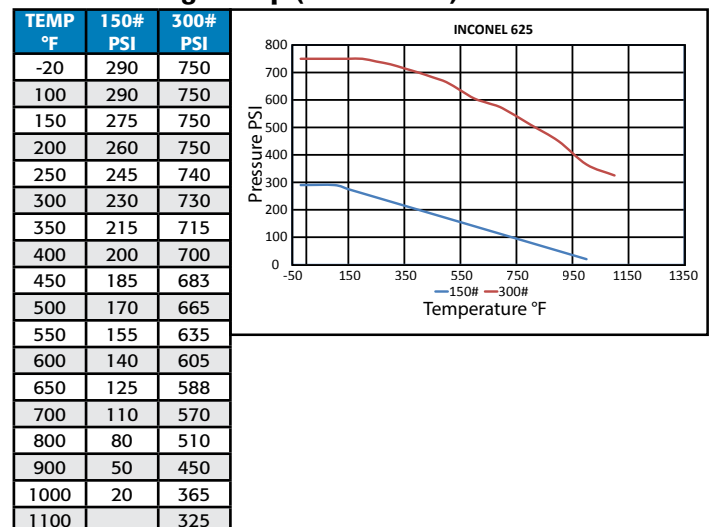

## Part Number Matrix for **POWER-SEAL** High Performance Butterfly Valves

1 Valve Series	
PS	Power-Seal Soft seat (450° F)
PF	Power-Seal Firesafe Seat (450° F)
PM	Power-Seal Metal seat (600° F)
PH	Power-Seal Metal Seat High Temp (1100° F)

2 Body Material			
<i>blank</i>	(No Designation)= Stainless Steel (SST) Body		
C	Carbon Steel	5	LCB
A	Alloy 20	N	Inconel 625
M	Monel	B	Aluminum-Bronze
D	CD3MN Duplex SST	*	Other
W	Hastelloy C		

3 End Connection	
L1	150# Lug
L3	300# Lug
W1	150# Wafer with Guide Holes
W3	300# Wafer with Guide Holes

4 Valve Size			
0200	2"	1400	14"
0300	3"	1600	16"
0400	4"	1800	18"
0500	5"	2000	20"
0600	6"	2400	24"
0800	8"	3000	30"
1000	10"	3600	36"
1200	12"	4200	42"
		4800	48"

5 Seat Material			
P	PTFE	6	316L SST <i>(Standard on PM Series)</i>
R	RTFE <i>(Standard)</i>	7	Inconel 625 <i>(Standard on PH Series)</i>
S	50/50 STFE	F	RTFE/ 316L SST <i>(Standard on PF Series)</i>
Z	PEEK		
U	UHMWPE		

6 Disc Material/Style	
S	316 SST <i>(Standard on CS and SST body)</i>
X	Same as Body Material
7	316 SST/Stellite <i>(Standard on PH Series)</i>
6	316 SST/HCr <i>(Standard on PM &amp; PF Series)</i>

7 Stem Bearing	
R	Teflon® Composite <i>(Standard on PS Series)</i>
C	Carbon Graphite <i>(Standard on PM/PH &amp; PF Series)</i>
B	Bronze
*	Other

8 Operator Designation	
X	Bare Stem
H	Standard 10 point Handle
G	Gear Operator

9 Stem	
A	17-4 pH Stem <i>(Standard)</i>
X	316 SST Stem
B	XM-19
*	Other

10 Packing (Live Loaded)	
G	Graphite <i>(Standard)</i>
P	Double PTFE V-Ring
V	Double PTFE Inverted V-Ring (Vacuum Service)
D	Pressure/Vacuum V-Ring

## How To Order **POWER-SEAL** High Performance Butterfly Valves

How To Order Manual Power-Seal High Performance Butterfly Valves	
1 2 - 3 - 4 - 5 6 7 - 8 9 10	
↓ ↓ ↓ ↓ ↓ ↓ ↓ ↓ ↓ ↓	
PSC - W1 - 0300 - R S R - X A G	

How To Order Automated Power-Seal High Performance Butterfly Valves	
1 2 - 3 - 4 - 5 6 7 - 8 9 10/ actuator size - options	
↓ ↓ ↓ ↓ ↓ ↓ ↓ ↓ ↓ ↓ ↓ ↓	
PSC - W1 - 0300 - R S R - X A G/ 2R5S - XX	
(see Actuator Size Legend & Automated Accessories)	

Pneumatic Accessories



Stainless Steel Actuators



Solenoids, Positioners, Limit Switches, Lock Up Valves, Declutchable Gear Operators, Speed Controls, Quick Exhaust Valves and more

Electric Actuator Options & Features



Explosion Proof

Options Specification

- Voltage Options: 110VAC, 220 VAC, 24 VDC/VAC, 12 VDC, 440 VAC, 460 VAC, 480 VAC
- Potentiometer unit (1K)
- (TMC) Electronic Modulating Card
- 4-20mA, 1-5mA, 0-10 VDC, 1-5 VDC, 0-135 Ohm Command Signal
- Current position transmitter (Output 4~20mA DC)
- Multi (24 VAC/DC)
- DC motor (24 VDC)
- Local control unit: remote/local/stop and open/close



TMC3 Electronic Modulating Card

- Auto Calibration for easy setup
- 10 Bit Microprocessor controller for precise positioning and control
- 4-20mA, 1-5mA, 0-10 VDC, 1-5 VDC, 0-135 Ohm or Command Signal Potentiometer
- TMC3 Can be programmed to Fail in Place, Fail CW, or Fail CCW on loss of command signal
- Characterized Control-Linear, quick opening (Square root), or Equal Percentage (Square)
- OnBoard 4-20 mA transmitter (optional)
- AS-i Network Card
- Boiler Feedwater Application



# **POWER-SEAL**

Manual and Automated  
High Performance Butterfly Valves  
ANSI/ASME Class 150# and 300#



  
**A-T Controls, Inc.**

9955 International Blvd.  
Cincinnati, Ohio 45246  
P: 513 - 247 - 5465  
F: 513 - 247 - 5462  
sales@atcontrols.com  
www.atcontrols.com

HPBV-20150302  
Copyright 2013 A-T Controls, Inc.  
LIT0035